

LOADING TECHNIQUE FOR THE STAAR 3-PIECE LENSES

MODELS: AQ1016V, AQ2003V, AQ2010V, AQ2017V & AQ5010V

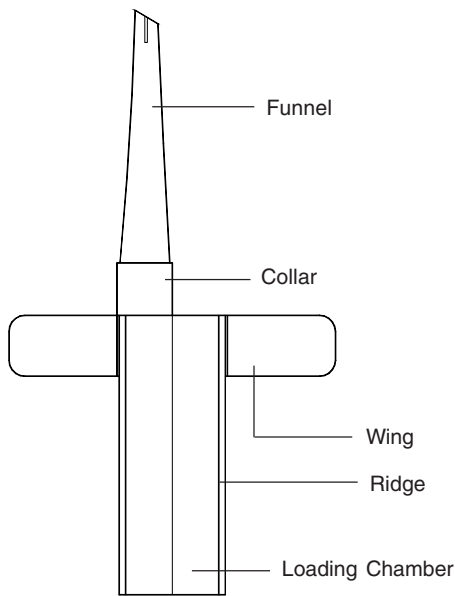

CARTRIDGE

1. Flush cartridge with BSS. Fill funnel and loading chamber with viscoelastic.

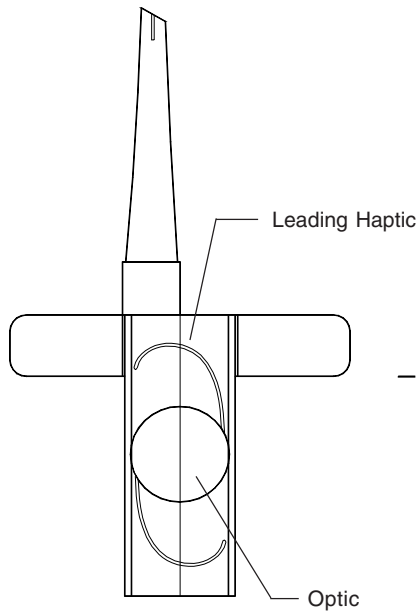

LENS POSITION

2. Using blunt utility forceps (to prevent damage to the lens), place lens in the loading chamber with the leading haptic pointing to the left (Reverse "S").

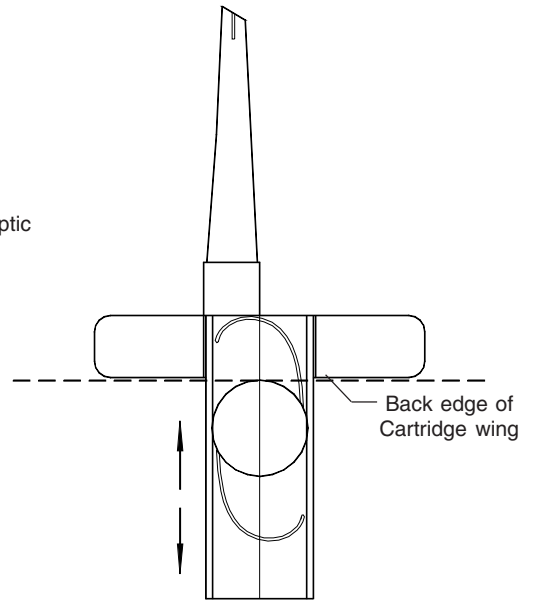

3. With the "feet" of the forceps on the optic, move lens forwards and backwards to make sure lens is well lubricated.
4. Align top of optic with the back-edge of cartridge wings as shown.

USE ONLY SMOOTH UTILITY FORCEPS TO PREVENT DAMAGE TO THE LENS

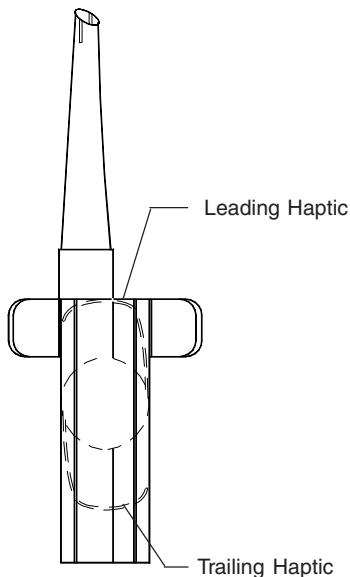

CLOSURE

5. Place forceps on top of the optic and close the cartridge wing half way then, tuck the leading haptic under the ridge and close the cartridge wings together.

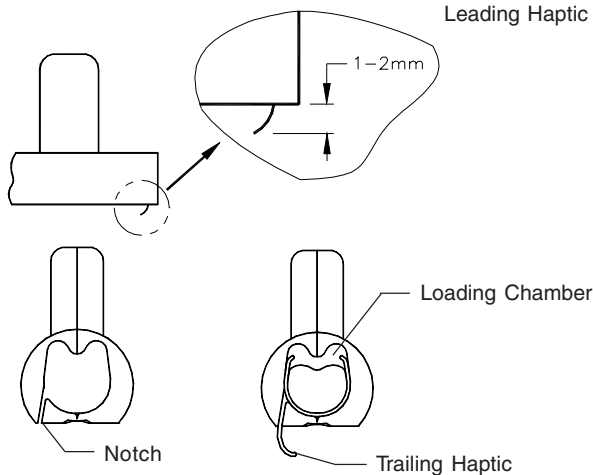

LENS POSITION (cross section)

6. After cartridge is closed, move the trailing haptic to the left until it falls into the haptic notch. Make sure trailing haptic does not extend more than 1 to 2 mm below the cartridge as shown above.

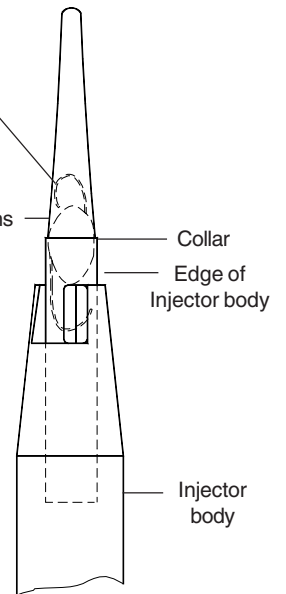

INJECTOR

7. Snap-Lock the folded cartridge in the blue capped plastic injector.
 8. Advance lens forward until the leading haptic is visible in the funnel. **Always** verify the presence of the haptics before implantation.
- Note: Trailing haptic should always be to the left of the injector head.**



LOADING TECHNIQUE FOR THE STAAR SINGLE PIECE LENSES

MODELS: AA4203VF, AA4204VF, AA4204VL, AA4203TF, AA4203TL AND AA4207VF

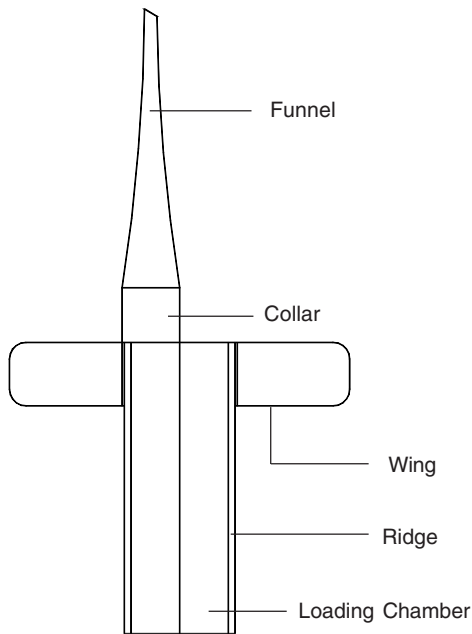

CARTRIDGE

1. Flush cartridge with BSS. Fill funnel and loading chamber with viscoelastic.

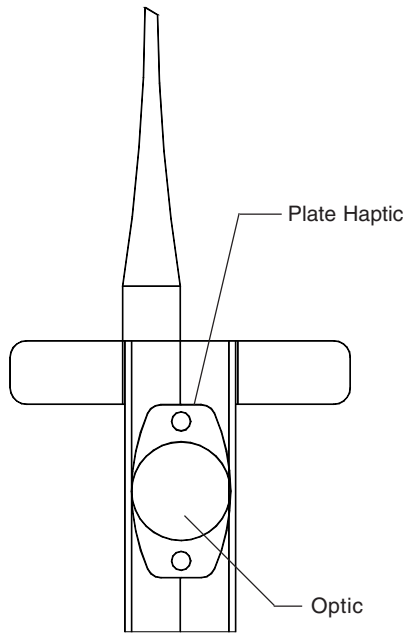

LENS POSITION

2. Using blunt utility forceps (to prevent damage to the lens), place and center lens in the loading chamber. Make sure long edges of the optic are tucked under the cartridge ridges on each side.

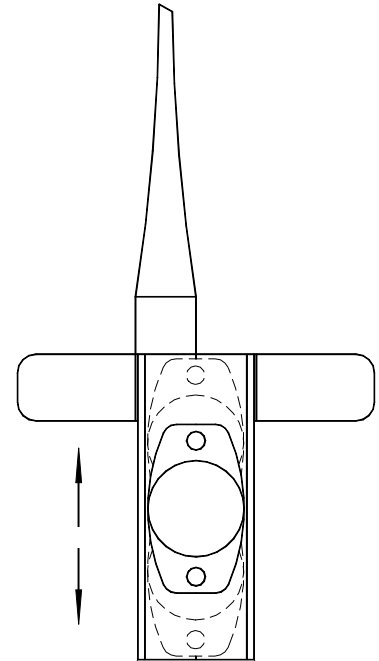

3. With the "feet" of the forceps on the optic, move lens forwards and backwards to make sure lens is well lubricated.
4. Center lens once more verifying placement under ridges.

USE ONLY SMOOTH UTILITY FORCEPS TO PREVENT DAMAGE TO THE LENS

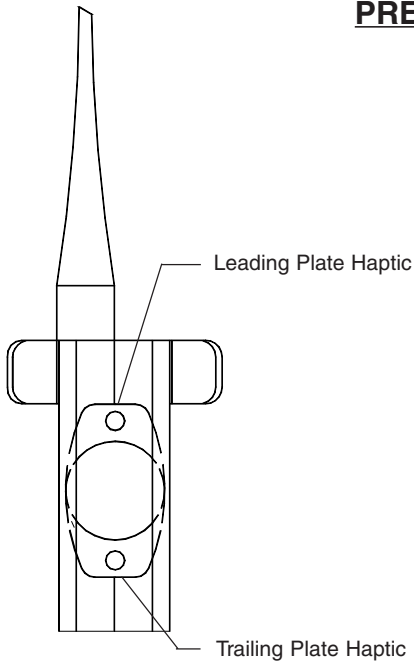

CLOSURE

5. Place forceps on top of the optic and close the cartridge wing.

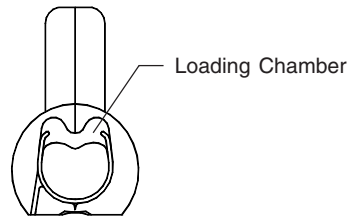

LENS POSITION (cross section)

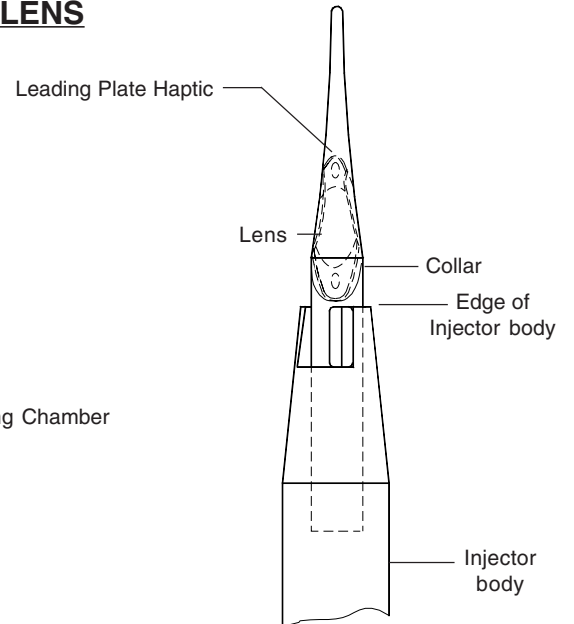

INJECTOR

6. Snap-Lock the closed cartridge in the MSI-PR or MSI-TR (white capped plastic injector).
* 7. Advance lens forward until it is visible in the funnel and the lens rests past the collar area as shown above.
8. Take 2-3 full turns forward and backward again to ensure the injector head does not override the lens.

* Lens should not be difficult to advance. If it is, get a new cartridge and reload.

